



(shown with optional flex-stand)



**MS7220 ArgusSCAN<sup>®</sup>** is an on-counter, hands-free bar code scanner. The omnidirectional scan pattern creates a large scan area, maximizing performance in medium-to-high throughput POS applications. **ArgusSCAN<sup>®</sup>**'s versatile mounting options, durability, and compact size make it adaptable to a variety of applications.

# MS7220 ArgusSCAN<sup>®</sup>

## Features

- A dense, omnidirectional scan area
- User-replaceable, single cable interface to host
- RS232 auxiliary port for adding peripherals such as a hand-held scanner or receipt printer
- Easy to set up and configure using either a Windows-based program or bar code scanning based guide
- Custom edit the bar code data
- Programmable depth of field - set the scan area to meet the application requirements
- OPOS and JPOS system compatible



**Metrologic's MS7220 ArgusSCAN** is an aggressive omnidirectional laser bar code scanner. Fully automatic scanning operation makes it ideal for retail, convenience, liquor, grocery and specialty stores. Because it is engineered with a large, high-speed scan area and a bright 650 nm laser, ArgusSCAN boasts exceptionally high first pass read accuracy for maximum productivity.

Offering four stand configurations, the ArgusSCAN is adaptable to a variety of applications. The modular design allows it to be mounted on a counter, in a horizontal or vertical configuration. An optional flex-stand can be added, raising the scanner an additional 76 mm (3") off the counter top. Combine this with the MS7220's program-

mable depth of field, and ArgusSCAN can be customized to meet the requirements of even the most unique scanning environment.

Multiple interfaces and data parsing make the ArgusSCAN compatible with most cash registers right out of the box, and the RS232 auxiliary port allows for check readers, magstripe readers or bar code scanner input. Simply plug a Metrologic hand-held scanner into the auxiliary port for scanning bulky or heavy items.

The MS7220 is OPOS and JPOS compatible and with Metrologic's PowerLink user replaceable cables, users can quickly replace cables if they become damaged.



# MS7220 ArgusSCAN®

## OPERATIONAL

Light Source	Visible Laser Diode 650 nm $\pm$ 10 nm
Laser Power	0.678 mW (peak)
Depth of Scan Field	0 mm - 215 mm (0" - 8.5") for 0.33 mm (13 mil) bar code
Width of Scan Field	38 mm (1.5") @ 40 mm (1.6"); 135 mm (5.3") @ 215 mm (8.5")
Scan Speed	2000 scan lines per second
Scan Pattern	5 fields of 4 parallel lines (omnidirectional)
Number of Scan Lines	20
Minimum Bar Width	0.13 mm (5.2 mil)
Decode Capability	Autodiscriminates all standard bar codes; for other symbologies call Metrologic
System Interfaces	PC Keyboard Wedge, RS232, OCIA, Light Pen Emulation, IBM 468x/469x, Stand Alone PC Keyboard, USB (low speed and full speed)
Print Contrast	35% minimum reflectance difference
Number Characters Read	Up to 80 data characters
Roll, Pitch, Yaw	360°, 60°, 60°
Beeper Operation	7 tones or no beep
Indicators (LED)	Green = laser on, ready to scan; Red = good read, decoding

## Scan Area

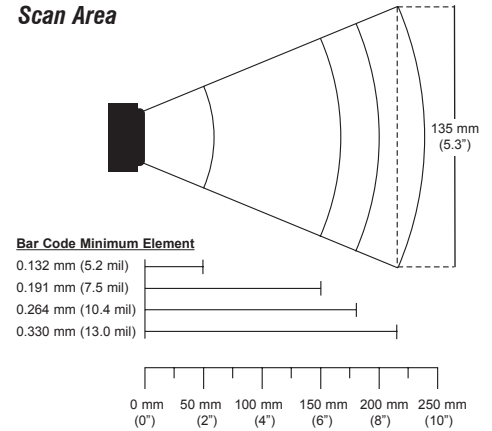

## Dimensions

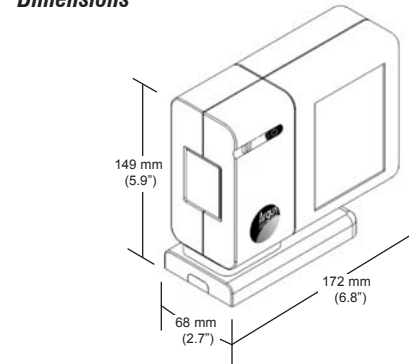

## with optional stand

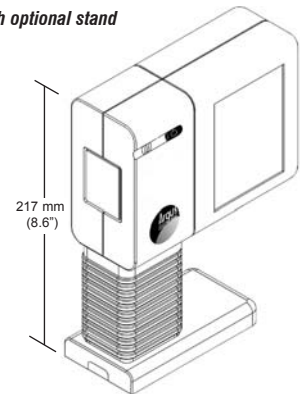

## MECHANICAL

Dimensions	149 mm H x 68 mm D x 172 mm W (5.9" H x 2.7" D x 6.8" W)
Footprint On Stand	127 mm x 68 mm (5.0" x 2.7") or 93 mm x 68 mm (3.5" x 2.7")
Weight	0.91 kg (2 lbs)
Termination	Four 10-pin modular RJ45
Cable	Standard 2.1 m (7') straight; optional 2.7 m (9') coiled; for other cables call Metrologic
Mount (optional)	Fully adjustable

## ELECTRICAL

Input Voltage	5.2 VDC $\pm$ 0.25 V
Power	1.9 W
Operating Current	360 mA
DC Transformers	Class II; 5.2 VDC @ 1 A
Laser Class	CDRH: Class IIa; EN60825-1:1994/A11:1996 Class 1
EMC	FCC, ICES-003 & EN55022 Class A

## ENVIRONMENTAL

Operating Temperature	0°C to 40°C (32°F to 104°F)
Storage Temperature	-40°C to 60°C (-40°F to 140°F)
Humidity	5% to 95% relative humidity, non-condensing
Light Levels	Up to 4842 Lux (450 footcandles)
Contaminants	Sealed to resist airborne particulate contaminants
Ventilation	None required

ArgusSCAN is available in the following colors



www.metrologic.com

**USA**  
Tel. 1.800.ID.METRO  
info@metrologic.com

**Asia**  
Tel. 65.6842.7155  
info@sg.metrologic.com

**AOA (only)**  
Tel. 1.617.806.1400  
info@oaa.metrologic.com

**China (only)**  
Tel. 86.512.62572511  
info@cn.metrologic.com

**South America**  
Tel. 5511.5182.7273  
info@sa.metrologic.com

**Japan (only)**  
Tel. 81.03.3839.8511  
info@jp.metrologic.com

**Brazil (only)**  
Tel. 5511.5182.8226  
info@br.metrologic.com

**Europe**  
Tel. 49.89.89019.0  
info@europe.metrologic.com

Specifications subject to change without notice.  
Printed U.S.A., Copyright November 2002  
Metrologic, All rights reserved.



DS7220

Metrologic Instruments, Inc. | 90 Coles Road | Blackwood, NJ 08012-4683  
Telephone 856-228-8100 or 1-800-ID-METRO | Fax 856-228-6673